



PRODUCT DATA

Metal SDS Flanged Hex Head and Seal

Self Drilling Screw (SDS) #08-18

Applications	
<ul style="list-style-type: none"> • Metal to metal fixing • Wall cladding • Sheds • Pergolas • Roofing Sheet • Valley fixing • Valley Fixing 	

Material	 C1022 Hardened
-----------------	--

Finish	 Class 4
---------------	--

8 Gauge Hex Head and Seal

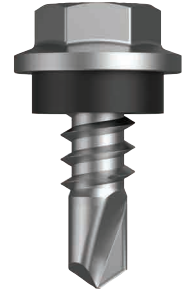

Pullout Values				
Plate (Purlin)	Metal Plate Thickness	¹ Mean Load	² Characteristic Load	³ Working Load
	(mm)	(N)	(N)	(N)
G2	0.7	950	800	300
G2	1.0	1550	1400	550
G550	1.5	3650	3150	1250
G450	2.0	4800	4150	1650
G450	2.5	6400	5450	2200

Drill Point Test					
Plate (Purlin)	Metal Plate Thickness	Load	Drill Speed	Drill Time	Drill Time
	(mm)	(kg)	(RPM)	(Max. individual) Seconds	(Max. average) Seconds
G550	1.5	18	2200	4.5	3

Mechanical Properties				
Torsional Strength	¹ Mean Tensile Strength	¹ Mean Shear Strength	² Characteristic Tensile Strength	² Characteristic Shear Strength
(Nm)	(N)	(N)	(N)	(N)
4.7	8050	4850	6750	4050

Note: 1000N = 1kN

¹ Mean Load/Strength is the average ultimate strength of samples tested.

² Characteristic Load/Strength: 95% of these screws are expected to have a strength greater than the loads shown.

³ Working Load is the governing minimum allowable load obtained by comparing relevant concrete and steel working loads. Factor of Safety (FOS=2.5 for steel, FOS=2.5 for timber and FOS=3.0 for concrete) are already included.

All values are obtained under laboratory conditions using DRILLX product. Safety factors should be considered for design purposes. Actual pullout loads may differ slightly depending on certain properties of the base material.

Disclaimer: While every reasonable effort has been made to ensure that this document is correct at the time of printing, Hobson Engineering®, its agencies and employees, disclaim any and all liability to any person in respect of anything or the consequences of anything done or omitted to be done in reliance upon the whole or any part of this document.



Bolt Tension | Anti-Vibration | Product Reliability | Traceability

hobson.com.au **QUALITY FASTENERS SINCE 1935**





PRODUCT DATA

Metal SDS Flanged Hex Head and Seal

Part	QFind	Gauge	TPI	Length	Thread Length	Drill Point Length	Head Height	Head ø	Drive Size	Pack Qty
				L (mm)	T (mm)	DP (mm)	H (mm)	D (mm)	AF (inch)	
T9PM4SH0818012	Q273	8	18	12	7	5	4	10	HEX 1/4"	1000

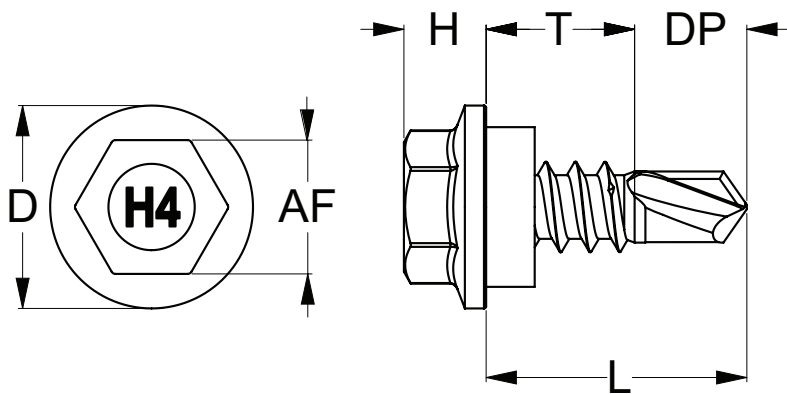

Installation

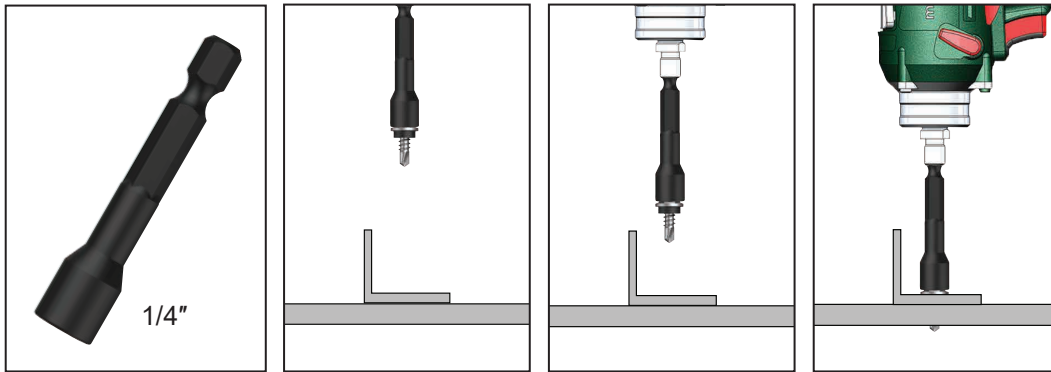

Recommended HEX 1/4 Drive Bit:

Part	QFind	Length (mm)
TXDDPNSS25045	B020	45
TXDDPNSS25065	B045	65

Installation Guide

1. Use a cordless screw driver set between 2,200-3,000 RPM. Fit the HEX Drive Bit over the screw and place at the fastening position.
2. Apply consistently firm pressure to the screw driver while the screw is drilling.
3. Care should be taken not to over-tighten the screw.

*Installation with impact drivers not recommended.

Disclaimer: While every reasonable effort has been made to ensure that this document is correct at the time of printing, Hobson Engineering®, its agencies and employees, disclaim any and all liability to any person in respect of anything or the consequences of anything done or omitted to be done in reliance upon the whole or any part of this document.

Bolt Tension | Anti-Vibration | Product Reliability | Traceability

hobson.com.au **QUALITY FASTENERS SINCE 1935**

