

ANSI 150lb/300lb THREADED, RAISED FACE ANSI FLANGES

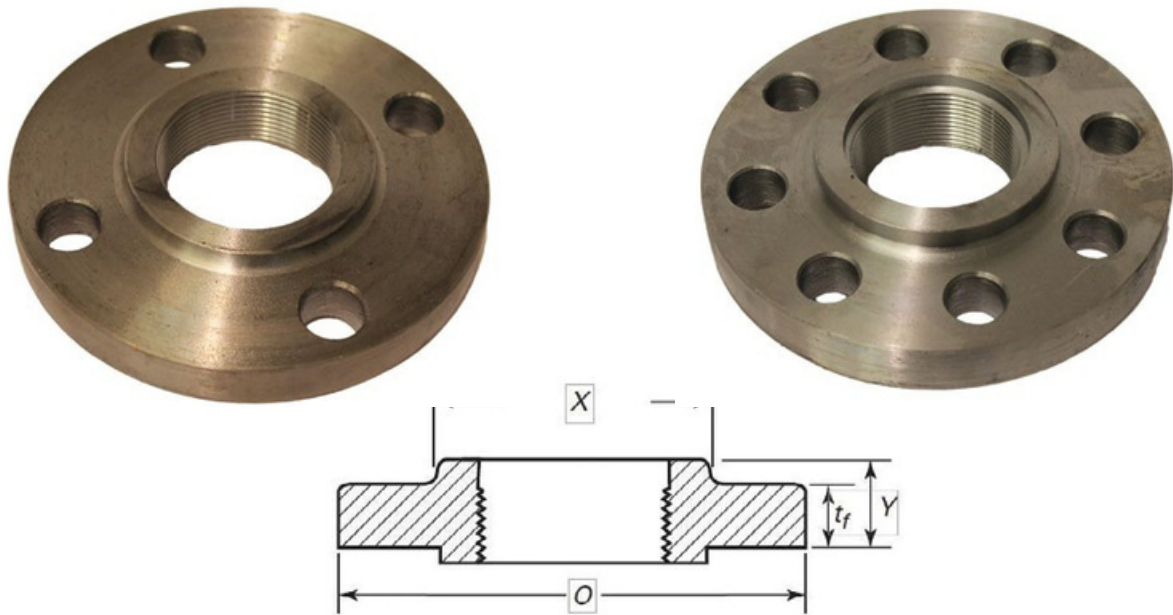

Nominal Pipe Size (mm)	PART NO. 150lb	OD of Flange D (mm)	Bolt Circle Diameter (mm)	Bolt Hole Diameter (in.)	Number of Bolt Holes	Thickness of Flange tf (mm)	Diameter of Hub X (mm)	Length of Hub Y (mm)	Weight Approx. (Kg)
15	150TH015	90	60.3	5/8	4	9.6	30	14	0.47
20	150TH020	100	69.9	5/8	4	11.2	38	14	0.58
25	150TH025	110	79.4	5/8	4	12.7	49	16	0.86
32	150TH032	115	88.9	5/8	4	14.3	59	19	1.08
40	150TH040	125	98.4	5/8	4	15.9	65	21	1.41
50	150TH050	150	120.7	3/4	4	17.5	78	24	2.26
65	150TH065	180	139.7	3/4	4	20.7	90	27	3.43
80	150TH080	190	152.4	3/4	4	22.3	108	29	3.87
100	150TH100	230	190.5	3/4	8	22.3	135	32	5.75

Nominal Pipe Size (mm)	PART NO. 300lb	OD of Flange D (mm)	Bolt Circle Diameter (mm)	Bolt Hole Diameter (in.)	Number of Bolt Holes	Thickness of Flange tf (mm)	Diameter of Hub X (mm)	Length of Hub Y (mm)	Weight Approx. (Kg)
15	300TH015	90	66.7	5/8	4	12.7	38	21	0.62
20	300TH020	115	82.6	3/4	4	14.3	48	24	1.15
25	300TH025	125	88.9	3/4	4	15.9	54	25	1.39
32	300TH032	135	98.4	3/4	4	17.5	64	25	1.67
40	300TH040	155	114.3	7/8	4	19.1	70	29	2.53
50	300TH050	165	127	3/4	8	20.7	84	32	2.8
65	300TH065	190	149.2	7/8	8	23.9	100	37	4.25
80	300TH080	210	168.3	7/8	8	27	117	41	5.81
100	300TH100	255	200	7/8	8	30.2	146	46	10.13

MATERIALS
ASTM A105
Forged Carbon Steel

SPECIFICATIONS
Ambient Pressure Rating
150lb PN20 / 300lb PN50
NPT thread as standard, BSP available

STANDARD
Dimensional
ASME B16.5